

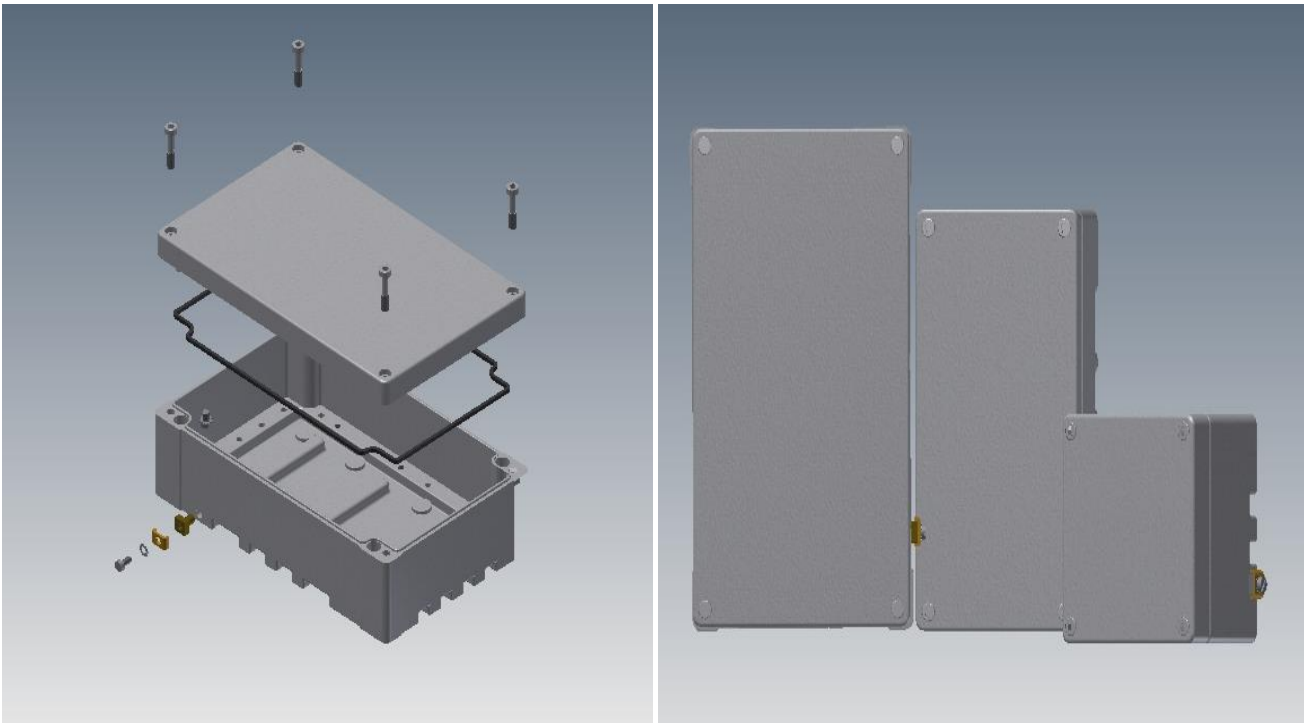

SHOMAL Engineering & Manufacturing Co.

OPERATING INSTRUCTIONS

LTB SERIES OF ALUMINIUM JUNCTION BOXES TYPES 120, 220, 260



**LTB SERIES 120-220-260**

**WI-17(PCD-P-01)/00**

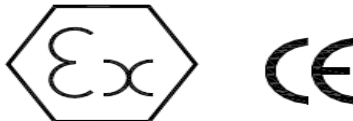

**THIS GUIDE SHOULD BE READ CAREFULLY BEFORE INSTALLATION.  
INCORRECT INSTALLATION AND USE OF THE ENCLOSURES CAN INVALIDATE  
THE GUARANTEE!**

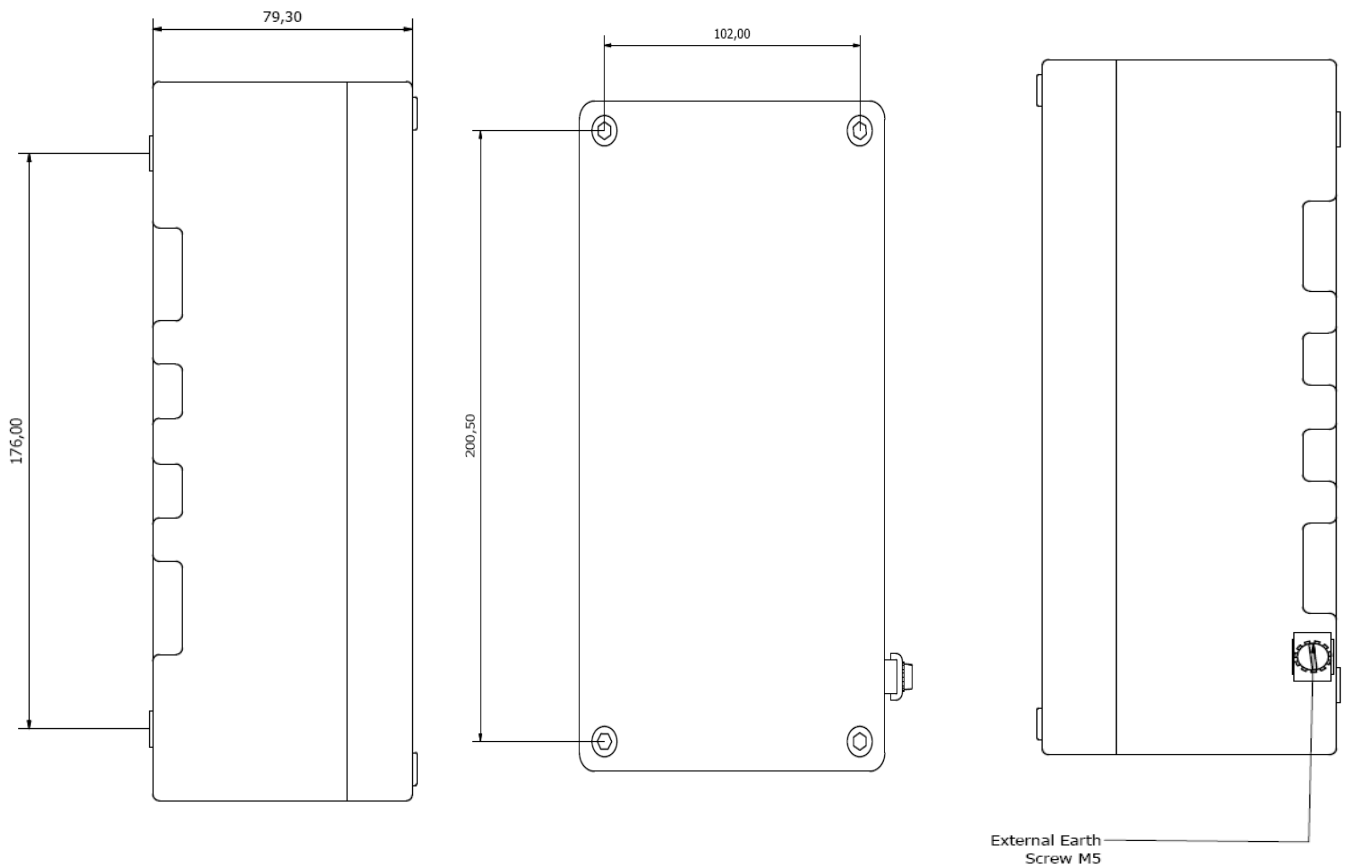

**LTB 220**

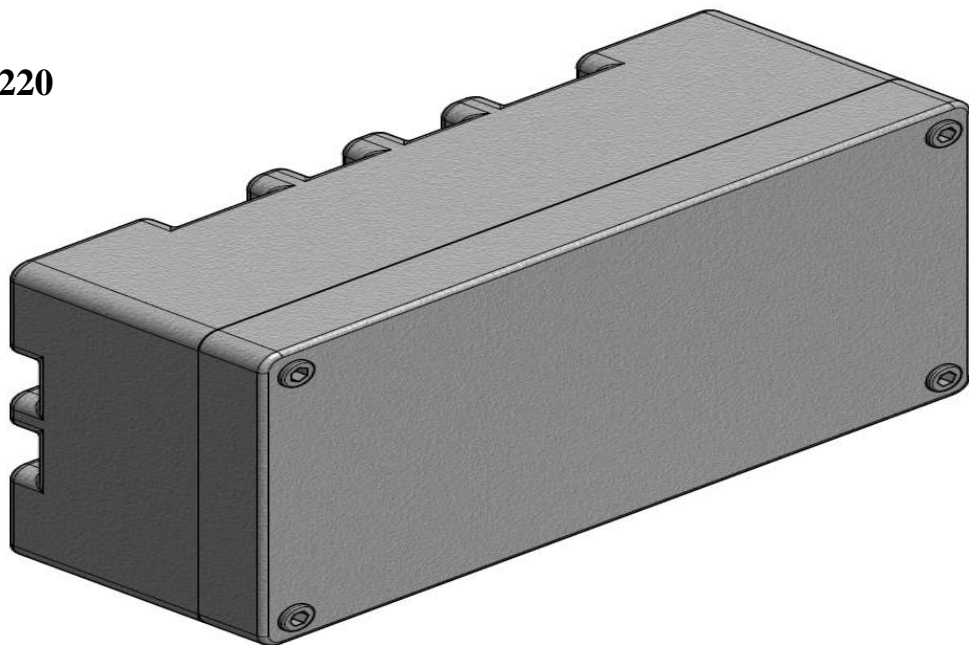

DIMENSIONS(mm)			
	EXTERNAL	INTERNAL	INSTALLATION HOLES CENTERS
LENGTH	220	209.4	176
WIDTH	122	111.5	106
HEIGHT	80	57	

## **IMPORTANT NOTES**

- 1) This guide should be read carefully before installation
- 2) Incorrect installation and use of the terminal boxes can invalidate the guarantee

## **CONFORMITY WITH STANDARDS**

The terminal boxes LTB 120, 220 and 260 meet the requirements of IEC 60079-0, IEC 60079-7, IEC 60079-31 and IEC 60529. 94/9/EC: equipment and protective systems intended for use in potentially explosive atmospheres.

the terminal boxes also fulfill further requirements such as those of the directive on electromagnetic compatibility (89/336/EEC). the terminal boxes have been designed, manufactured and tested according to the ISO 9001:2008.

## **SAFETY INSTRUCTIONS**



The enclosures are not suitable for zone 0 and zone 20 hazardous areas. The temperature class and explosion group marked on the terminal boxes shall be observed.

The apparatus shall not be used in dust layers > 50mm according to IEC 60079-31.

Modifications to the terminal boxes or changes of their design are not permitted. They shall be used for intended purpose and in perfect and clean condition.

For replacement and repair, only genuine SEMC spare parts shall be used.

Repairs that affect the explosion protection may only be carried out by SEMC or qualified electrician in compliance with the respective national regulations.

Prior to taking the terminal boxes into operation, they shall be checked in accordance with the “taking into operation “of this manual.

Before the initial operation, any foreign object shall be removed from the terminal boxes.

Observe the national safety rules and regulations for prevention of accidents as well as safety instructions included in this operating instruction.

## **FIELD OF APPLICATION**

CAT II 2G for use in zone 1 or zone 2 area as defined in IEC/EN 60079-14.

CAT II 2D for use in zone 21 or 22 area as defined in IEC/EN 60079-14.

## **AMBIENT TEMPERATURE**

-20°C to +40°C or -30°C to +55°C

## **PERMANENT STORAGE TEMPERATURE IN ORIGINAL PACKAGE**

-20°C TO +80°C

**MARKING**

ATEX Marking:

Ⓔ II 2 G D - IP66

Ex e IIC T6 Gb

Ex tb IIIC T85°C Db

IECEX Marking:

Ex e IIC T6 Gb

Ex tb IIIC T85°C Db

IP66

**TERMINAL BOX WATTAGE FACTOR CALCULATION METHOD:**

W= Maximum dissipated wattage,

N= No. of terminals fitted,

R=Combined terminal resistance,

I= Maximum current

$$W=N \times R \times I^2$$

$$N=W / R \times I^2$$

$$I= \text{Sqrt} (W / N \times R)$$

Note: Combined terminal resistance = resistance of maximum conductor length + terminal resistance

TABEL 1-MAXIMUM POWER DISSIPATION(WATTS)			
Box type	T6 T <sub>Amb</sub> =-20°C to +40°C	T6 T <sub>Amb</sub> = -30°C to +55°C	Maximum cable Length per terminal(M)
LTB 120	6.7	4.1	0.146
LTB 220	10.9	6.8	0.231
LTB 260	16	10	0.283

Typical cable resistances are given in Table 2, but may vary depending on the cable manufacturer. Terminal resistances are defined in Table 3 as per terminal certification data. EXAMPLE: Assume a terminal box which has a maximum dissipated power of 10.9 Watts. Consider 0.231 m length for its maximum internal linear dimension. The terminal box fitted with 25 SAK 2.5 terminals, operating at 7A each with 2.5mm<sup>2</sup> cable attached:

Resistance of conductor = 0.00741 Ω/m x 0.365 m= 0.0027Ω per conductor

Resistance of terminal = 0.00035Ω

Total resistance per terminal = 0.00035Ω+ 0.0027Ω= 0.00306Ω

Therefore p= 7<sup>2</sup> x 0.00306Ω x 25terminals = 3.74W

Since the maximum permitted dissipated power is measured at 10.9W, therefore the assembly of 25 SAK 2.5 terminals would be acceptable.

TABLE 3:Terminal Sizes & Resistance( $\Omega$ )			
Terminal Type/size	Terminal resistance	Terminal Type/size	Terminal resistance
WDU 1.5/ZZ	0.000862	ZDU 2.5/4AN	0.0005
WDU 2.5/1.5/ZR	0.000654	ZDU 2.5/2*2AN	0.00082
WDU 2.5	0.0002	ZDU 4	0.00041
WDU 2.5N	0.00031	ZDU 6	0.00027
WDU 4	0.00014	ZDU 2.5/1.5	0.00082
WDU 6	0.00009	UK 1.5N	0.0004571
WDU 10	0.000075	UK 2.5N	0.0004166
WDU 16	0.00005	UK 3N	0.0005
WDU 35	0.000028	UK 5N	0.000375
WDU 50N	0.00005	UK 6N	0.000158
SAK 2.5	0.00035	UK 10N	0.0001228
SAK 4	0.0003	UK 16N	0.000171
SAK 6N	0.0002	UK 35	0.000088
SAK 10	0.00004	UKH50	0.0001
SAK 16	0.000023	RTP 2.5	0.000025
SAK 35	0.000092	RTP 4	0.0000203
ZDU 2.5	0.00065	RTP 6	0.0000129
ZDU 2.5/3AN	0.00069	RTP 10	0.0000114

TABLE 2:Conductor resistance	
conductor size (mm <sup>2</sup> )	resistance
0.5	0.036
0.7	0.0258
1	0.0181
1.5	0.0121
2.5	0.00741
4	0.00461
6	0.00308
10	0.00183
16	0.00115
25	0.000724
35	0.000524

Table 4. Terminal capacity data								
Terminal type	size mm <sup>2</sup>	CERTIFICATION NO.		current	Volt	Max.No. of Terminals Horizontal(H)/vertical(V)		
						LTB120	LTB220	LTB260
WDU 1.5/ZZ	0.5/2.5	KEMA 98ATEX 1685 U	IECEX ULD 05.008 U	15	550	7	40/35	56/45
WDU 2.5/1.5/ZR	0.5/4	KEMA 98ATEX 1685 U	IECEX ULD 05.008 U	20	550	10	40/35	56/48
WDU 2.5	0.5/4	KEMA 98ATEX 1685 U	IECEX ULD 05.008 U	20	550	10	40/35	56/48
WDU 2.5N	0.5/4	KEMA 98ATEX 1685 U	IECEX ULD 05.008 U	20	440	10	40/35	56/48
WDU 4	0.5/6	KEMA 98ATEX 1685 U	IECEX ULD 05.008 U	28	690	8	34/29	46/40
WDU 6	0.5/10	KEMA 98ATEX 1685 U	IECEX ULD 05.008 U	36	550	6	26/23	36/31
WDU 10	1.31/16	KEMA 98ATEX 1685 U	IECEX ULD 05.008 U	50	550	-	20/18	28/24
WDU 16	1.5/25	KEMA 98ATEX 1685 U	IECEX ULD 05.008 U	63	690	-	16/15	24/20
WDU 35	2.5/50	KEMA 98ATEX 1685 U	IECEX ULD 05.008 U	109	750	-	-	16/15
WDU 50N	5.26/70	KEMA 98ATEX 1685 U	IECEX ULD 05.008 U	153	750	-	-	14/13
SAK 2.5	0.5/6	KEMA 97ATEX 1798 U	IECEX KEM 06.0014 U	21	550	8	34/30	46/41
SAK 4	0.5/6	KEMA 97ATEX 1798 U	IECEX KEM 06.0014 U	28	550	7	32/28	44/37
SAK 6N	0.5/10	KEMA 97ATEX 1798 U	IECEX KEM 06.0014 U	36	550	6	26/22	34/30
SAK 10	1.5/16	KEMA 97ATEX 1798 U	IECEX KEM 06.0014 U	50	550	-	10/18	28/24
SAK 16	2.5/16	KEMA 97ATEX 1798 U	IECEX KEM 06.0014 U	66	690	-	16/15	22/20
SAK 35	6/50	KEMA 97ATEX 1798 U	IECEX KEM 06.0014 U	125	800	-	-	14/13
ZDU 2.5	0.5/4	KEMA 97ATEX 2521 U	IECEX ULD 05.0009 U	20	550	10	40/35	56/48
ZDU 2.5/3AN	0.5/2.5	KEMA 97ATEX 2521 U	IECEX ULD 05.0009 U	20	550	10	40/35	56/48
ZDU 2.5/4AN	0.5/2.5	KEMA 97ATEX 2521 U	IECEX ULD 05.0009 U	20	550	10	40/35	56/48

ZDU 2.5/2*2AN	0.5/4	KEMA 97ATEX 2521 U	IECEX ULD 05.0009 U	20	550	10	40/35	56/48
ZDU 4	0.5/6	KEMA 97ATEX 2521 U	IECEX ULD 05.0009 U	28	550	8	34/30	46/41
ZDU 6	0.5/10	KEMA 97ATEX 2521 U	IECEX ULD 05.0009 U	36	550	6	26/22	34/30
ZDU 2.5/1.5	0.5/2.5	KEMA 97ATEX 2521 U	IECEX ULD 05.0009 U	20	275	10	40/35	56/48
UK 1.5N	0.14/1.5	KEMA 98ATEX 1651 U	IECEX KEM 06.0034 U	17	275	12	50/43	68/58
UK 2.5N	0.2/2.5	KEMA 98ATEX 1651 U	IECEX KEM 06.0034 U	28	550	9	40/35	54/47
UK 3N	0.2/2.5	KEMA 98ATEX 1651 U	IECEX KEM 06.0034 U	28	750	9	40/35	54/47
UK 5N	0.2/4	KEMA 98ATEX 1651 U	IECEX KEM 06.0034 U	38	750	8	34/29	46/39
UK 6N	0.2/10	KEMA 98ATEX 1651 U	IECEX KEM 06.0034 U	53	750	6	26/22	34/30
UK 10N	0.5/10	KEMA 98ATEX 1786 U	IECEX KEM 06.0029 U	73	750	-	20/17	28/24
UK 16N	0.75/16	KEMA 98ATEX 1786 U	IECEX KEM 06.0029 U	88	750	-	16/14	22/20
UK 35	0.75/35	KEMA 98ATEX 1786 U	IECEX KEM 06.0029 U	145	750	-	-	18/16
UKH50	10/50	KEMA 98ATEX 1786 U	IECEX KEM 06.0029 U	135	750	-	-	14/12
RTP 2.5	0.5/4	KEMA 04ATEX 2265 U	N/A	24	400	8	34/30	46/41
RTP 4	0.5/4	KEMA 04ATEX 2265 U	N/A	32	400	7	32/28	44/38
RTP 6	0.5/10	KEMA 04ATEX 2265 U	N/A	41	800	6	26/22	34/30
RTP 10	0.5/16	KEMA 04ATEX 2265 U	N/A	57	500	-	20/18	28/24
RTP 16	0.5/16	KEMA 04ATEX 2265 U	N/A	76	500	-	16/14	22/19

## TO OPEN THE LID

1. Disconnect power, (isolate all circuits).
2. Un-tighten all of M6 lid's screws.
3. Carefully open the lid, ensuring the sealing gasket is not damaged or misplaced then disconnect the earth from the lid.

## **TO CLOSE THE LID**

Any foreign object shall be removed from the apparatus.

Check that the sealing gasket is secured inside the lid, and undamaged. Make sure that the lid is refitted correctly.

Locate and tighten the M6 lid screws using 2 Nm torque for first pass and 4 Nm for final pass or (tighten up the screws until it stops for the first pass then re-tighten by quarter ‘%’ of a turn for the final path).

**WARNING!!!:** If the screws are over tightened, the apparatus can be damaged!

## **ENCLOSURE INSTALLATION FOR SAFE USE**

1. The IP rating of the enclosure must be maintained for the area of use, by the use of correct arrangement of Cable /gland /sealing arrangements and in accordance with the installation codes as detailed in IEC 60079-14, IEC 60079-31, and this operating instruction.
2. | Where other certified components are part of assembly, the user must take in to account any limitations listed on relevant certificates.
3. If an optional Breather/Drain as listed in the enclosure certificate is fitted, the enclosure must be sited such that the Breather/Drain is pointing vertically downwards from its bottom. The operating temperature range of the enclosure is limited to that of the breather / drain device fitted.
4. The IP rating of the Breather Drain should match with the IP rating of the enclosure.
5. | Unused entry holes shall be fitted with stopping plugs as specified in the component (empty) enclosure certificates TUV12ATEX7193U . The operating temperature range of the enclosure is limited to that of the stopping plug fitted.

Unused entries may be fitted with alternative stopping plugs and/or breather drains to those listed in the schedule. The user is responsible for ensuring that the protection concept temperature class and relevant IP rating are maintained.

6. When used under dust layers the maximum depth shall be no greater than 50mm.
7. The enclosure has Metric clearance/plain entry holes as standard. Alternative clearance holes are available. Plain entry holes must maintain the following:
  - a) The plain hole shall be no larger than 0.7mm above the major diameter of the entry thread.
  - b) Glands or stopping plugs shall be secured internally by suitable locknuts, such that they will not be dislodged by a 7Nm impact.
  - c) The enclosure shall be maintained at IP 66 by a suitable sealing washer under the shoulder of the cable gland and or entry devices. (Cable glands and or entry devices must be certified)

The apparatus must not be modified without reference to SEMC, as this will invalidate certification.

### **TERMINAL WIRING (TW)**

- 1) All wiring must be carried out in accordance with the relevant code of practice and/ or instruction e.g. BS EN 60079-14
- 2) All terminals and accessories such as cross-connectors, shall be installed in accordance with the terminal manufacturer's instructions.
- 3) The voltage and current and maximum dissipated power shown on the label must not exceed.
- 4) Where a major portion of the terminals are carrying maximum rated current the temperature at the branching point of the conductors may exceed 70° C. Under this circumstances the installer must insure that the limiting temperature for the cable insulation used acceptable e.g. 85° C (T6).
- 5) The wiring installation must extend to within 1mm of the metal face of the terminal, unless the relevant certificate allows more. (See terminal schedule for limitations).
- 6) All leads must be insulated for the appropriate voltage.
- 7) Terminal temperatures must not exceed the operating range specified on the component certificate.
- 8) Not more than one single or multiple standard lead shall be connected into either side of the terminals, unless the relevant component certificate allows more, or unless the multiple conductors have been previously joined in a suitable manner (for example with an insulated crimped boot lace ferrule, mounted in a vertical position) such that they form a single cohesive item for insertion into a terminal way. A parallel shaft screw driver of the correct size should be used.
- 9) Only those terminals shown on terminal schedule attached may be incorporated in the box. (See table 4)
- 10) The installer must insure that the condition of use for the terminals outlined is complied with the relevant certificate.
- 11) All terminal screws used and unused shall be fully tightened down by the end user.
- 12) The installer shall ensure creep age and clearance distance are not reduced, especially between intrinsically safe (is) and non-is circuits (e.g. 50mm clearance).
- 13) The use of any cross connection devices between adjacent terminal ways shall be in accordance with the requirements of the relevant component certificate listed on held on.
- 14) Use of the terminal box at ambient temperature below -20°C is dependent upon the minimum service temperature of the terminals.

- 15) When connecting a terminal with a conductor that is below the maximum cross section area maximum amps/pole must be reduced in line with the maximum amps indicated for the terminal equivalent to the conductor size being fitted e.g. for a terminal that can take a maximum conductor size of 10mm<sup>2</sup> at 50 amps, but is fitted with a 4mm<sup>2</sup> conductor then the current shall be reduced to maximum a 21 amps, or the rating on the terminal box lid label (whichever is the lowest).

## **EARTHING**

These enclosures have an integral internal and external earth MS screw suitable for the largest conductor (Up to 35mm<sup>2</sup>) size used in the box.

In the case of painted boxes, consideration must be given to the removal of paint e.g. under the earth stud on the inside of the box which may lead to corrosion of the enclosure and potential reduction in earth protection. This area following installation must be protected against corrosion,

## **TAKING INTO OPERATION**

Prior to taking the apparatus into operation, the test specified in the relevant national regulations will have to be carried out.

Apart from that, the correct functioning and installation of the apparatus in accordance with this operating instruction and other applicable regulations will have to be checked.

Incorrect installation and use of the terminal box can invalidate the guarantee.

## **SPECIAL CONDITIONS FOR SAFE USE**

- Suitable certified cable glands or blanking elements, that sustain the type of protection and IP66, must be used.
- If a breather is equipped, the lower IP rating is used instead.
- The insulation of conductors must match with temperature requirements

## **MAINTENANCE / SERVICING**

The relevant national regulations which apply to the maintenance/servicing of the electrical apparatus in explosive atmosphere shall be observed.

Before opening the enclosure make sure that the apparatus is disconnected from the supply voltage, or take appropriate protective measures. The required maintenance intervals depend on the respective application and will therefore have to be determined by the user dependent on the conditions of use. Additional periodic checks that are advisable to ensure the efficiency of SEMC "LTB" range enclosures are:

Activity		Frequency
1	Check that the lid seal is in place and not damaged	Each time the enclosure is opened
2	that all lid fixing screws are in place and secured	Each time the enclosure is closed
3	Check that the mounting bolts are tight and free of corrosion	Annually
4	Check the security of all cable glands	Annually
5	Check for damage of the enclosure	Annually
6	Check for corrosion of the enclosure	Annually Every 3 months in corrosive Atmospheres (recommended)

When servicing the apparatus, particularly those parts that are decisive for the type of protection against explosion, will have to be checked (e.g. intactness of enclosure, cable glands, efficiency of the cover gaskets).

If during servicing repairs prove to be necessary, the Repair / Overhaul / Modification of this manual will have to be observed.

### **REPAIR / OVERHUAL / MODIFICATION**

Repairs may only be carried out with genuine SEMC spare parts.

Repairs that affect the explosion protection may only be carried out by SEMC or a qualified electrician in compliance with the applicable rules. Modifications to the apparatus or changes of its design are not permitted.

### **DISPOSAL / RECYCLING**

When the apparatus is disposed of, the respective national regulations on waste disposal will have to be observed.

### **SPECIAL CONDITIONS FOR SAFE USE**

- Suitable certified cable glands or blanking elements, that sustain the type of protection and IP66, must be used.
- If a breather is equipped, the lower IP rating is used instead.
- The insulation of conductors must match with temperature requirements